



TIEMME

TUBO MULTISTRATO INGUAINATO AL-COBRAPEX PIPE WITH SHEAT

Art. 0640

TUBO MULTISTRATO CON GUAINA CORRUGATA (disponibile rosso o blu)
MULTILAYER PIPE WITH CORRUGATED SHEAT
(available in red or blue)

Tubo multistrato Al-Cobrapex (vedere scheda tecnica 0660 per maggior informazioni) con guaina corrugata per la protezione del tubo.

Multilayer pipe (see technical sheet 0660 for more information) with corrugated sheat for pipe protection.



Per la gamma completa vedere il catalogo / For complete range see catalogue



Certificazioni / Certifications

Certificazioni / Certifications

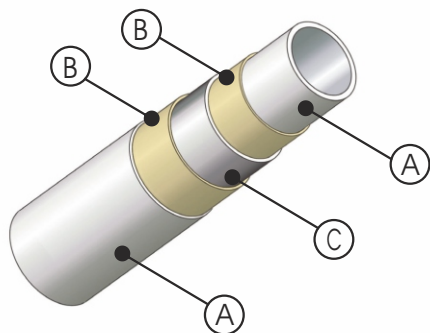

A : Strato in polietilene reticolato ad alta densità PE-Xb
High-density cross linked polyethylene PE-Xb layer

B : Strato adesivo
Adhesive layer

C : Strato intermedio in alluminio
Aluminium intermediate layer

Preparazione del tubo per giunzione con raccordi *Pipe preparation for fitting joint*

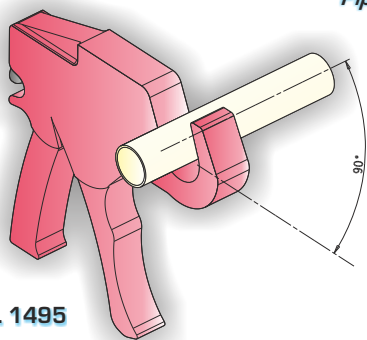

Art. 1495

Per ottenere una perfetta giunzione si devono eseguire alcune semplici ma importanti operazioni :

1) per prima cosa si deve procedere al taglio del tubo alla misura desiderata. Per effettuare il taglio è consigliabile utilizzare una cesoia tagliatubi Art. 1495, facendo in modo che il taglio sia eseguito il più perpendicolare possibile rispetto all'asse del tubo stesso;

In order to obtain a perfect joint the following simple but important operation must be carried out :

1) first of all cut the pipe to the required length using the pipe cutter Art. 1495, the cut shall be as perpendicular as possible to the pipe axis ;

2) è necessario quindi procede alla sbavatura e calibratura del tubo utilizzando l' utensile Art. 1498.. della misura idonea al tubo in uso. L' utensile va inserito nel tubo e quindi fatto ruotare in senso orario fino ad ottenere delle estremità senza bave e perfettamente calibrate.

2) then it is very important to clean and ream the pipe using the tool Art. 1498.. of the correct size of the tube in use. The tool must be inserted in the pipe and then rotated clockwise until the bevel appear without any imperfection and the pipe is perfectly calibrated.

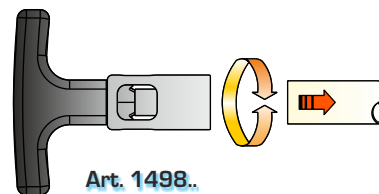

Art. 1498..

TIEMME Raccorderie S.p.A. si riserva di apportare modifiche in qualsiasi momento senza preavviso.
TIEMME Raccorderie S.p.A. reserves the right to modify contents in any time without prior advise.
È vietata qualsiasi forma di riproduzione, se non autorizzata.
is forbidden any reproduction unless under TIEMME autorization



TIEMME Raccorderie S.p.A.
Via Cavallera 6/A (Loc. Barco) - 25045 Castegnato (Bs) - Italy
Tel +39 030 2142211 R.A. - Fax +39 030 2142206
info@tiemme.com - www.tiemme.com

©TIEMME Raccorderie S.p.A. 0640 Rev. B 10-11





TIEMME

TUBO MULTISTRATO INGUAINATO AL-COBRAPEX PIPE WITH SHEAT

Art. 0640

Accessori (vedere il catalogo per ulteriori dettagli)

Accessories (see catalogue for further details)

Art. 0625



Calza in PVC trasparente
Transparent PVC seal



Art. 1495

Cesoia taglia tubi Ø0+Ø35
Pipe cutter Ø0+Ø35

Art. 1496



Cesoia taglia tubi Ø14+Ø20
Pipe cutter Ø14+Ø20

Art. 1497



Molla curva tubo
Pipe bending spring



Art. 1498SET

Set calibratori/sbavatori Ø14+Ø40
Pipe deburring tool set Ø14+Ø40

Art. 1498UM



Utensile calibratore/sbavatore
con impugnatura fissa
Deburring tool with fixed "T" handle

Art. 1498US



Utensile calibratore/sbavatore intercambiabile
Interchangeable deburring tool

Art. 1498MT



Impugnatura a "T" intercambiabile
Interchangeable "T" handle

Art. 1683



Cesoia taglia tubo con sbavatore
Pipe cutter with cleaner

Art. 1684



Set per curvatura tubi
Pipe bending set



Art. 1689

Raddrizza tubi
Straightening device

Art. 4530



Srotolatore tubo
Pipe deciler



TIEMME Raccorderie S.p.A.
Via Cavallera 6/A (Loc. Barco) - 25045 Castegnato (Bs) - Italy
Tel +39 030 2142211 R.A. - Fax +39 030 2142206
info@tiemme.com - www.tiemme.com

©TIEMME Raccorderie S.p.A. 0640 Rev. B 10-11



TIEMME Raccorderie S.p.A. si riserva di apportare modifiche in qualsiasi momento senza preavviso.
TIEMME Raccorderie S.p.A. reserves the right to modify contents in any time without prior advise.
È vietata qualsiasi forma di riproduzione, se non autorizzata.
is forbidden any reproduction unless under TIEMME authorization

