



TIEMME

CALIBRATORI / SBAVATORI DEBURRING TOOLS

Art. 1498

Utensili per calibratura e sbavatura tubo multistrato e tubo rame ricotto.

Deburring tools for multilayer pipes and soft copper pipes.

Gli utensili per la calibratura/sbavatura Tiemme sono la soluzione ottimale per la preparazione delle estremità dei tubi su cui andare a calzare i raccordi a stringere od a pressare.

Grazie alla configurazione dell' utensile si ottengono :

- la calibratura del diametro interno del tubo ;
 - la cianfrinatura della parte interna dell' estremità tagliata ;
 - la cianfrinatura della parte esterna dell' estremità tagliata ;
- inoltre grazie ai taglienti dell' utensile le operazioni si eseguono rapidamente e senza eccessivi sforzi.

Gli utensili intercambiabili Art. 1498US possono essere montati sul mandrino del trapano (max. 500 giri/min) per rendere ancora più veloci e facili le operazioni di preparazione dei tubi.

The Tiemme deburring tools are the best solution for the bevel preparation of pipe used with compression or press fittings.

Due to the tool configuration it may be possible to :

- calibrate the inside diameter of the pipe ;
- deburr the inside bevel of the cutted end ;
- deburr the outside bevel of the cutted end ;

furthermore due to tool cutting edges the bevel preparation operations are faster and easier.

The interchangeable tools Art. 1498US may be also installed on drilling machine (max. 500 U/min) to make more faster and easier the pipes bevel preparation.



Per la gamma completa vedere il catalogo / For complete range see catalogue

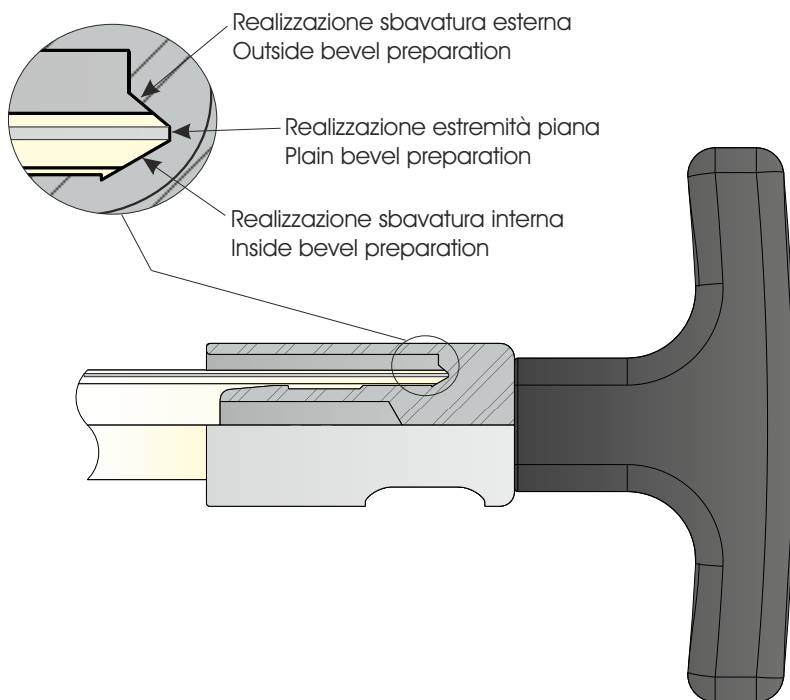

Descrizione

Corpo
Protezione
Impugnatura

Materiale

Acciaio
Acciaio
PA rinforzato con fibra di vetro

Description

Body
Protection
Handle

Material

Steel
Steel
Glass-fibre reinforced PA based

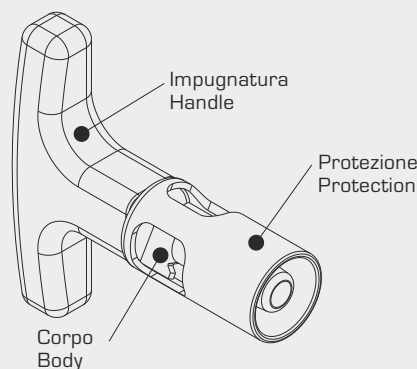

La conformazione dell' impugnatura e' stata studiata per rendere più sicura ed energica la presa. Il guscio di protezione del corpo utensile e' stato appositamente progettato e voluto in acciaio per evitare possibili danneggiamenti in caso urti o cadute anche da altezze considerevoli.

The handle desing have been defined in order to make more reliable and powerfull the grip. The body protection have been expressly desingned and made of steel in order to avoid damages.

TIEMME Raccorderie S.p.A. si riserva di apportare modifiche in qualsiasi momento senza preavviso. TIEMME Raccorderie S.p.A. reserves the right to modify contents in any time without prior advise. E' vietata qualsiasi forma di riproduzione, se non autorizzata. Is forbidden any reproduction unless under TIEMME autorization



TIEMME Raccorderie S.p.A.
Via Cavallera 6/A (Loc. Barco) - 25045 Castegnato (Bs) - Italy
Tel +39 030 2142211 R.A. - Fax +39 030 2142206
info@tiemme.com - www.tiemme.com





TIEMME

CALIBRATORI / SBAVATORI DEBURRING TOOLS

Art. **1498**



Art. 1498SET

Valigetta con set calibratori/sbavatori
Box with deburring tools set



Art. 1498UM

Calibratori/sbavatori con impugnatura fissa
Deburring tools with fixed handle



Art. 1498us

Utensili calibratore/sbavatore intercambiabili
per utilizzo con articolo 1498MT
da Ø14 a Ø40, con chiave esagonale
ch.10 per Ø50 e Ø63 oppure con trapano
*Interchangeable deburring tools to be used
with article 1498MT for Ø14+Ø40 sizes,
with pipe wrench exagonal ch. 10 for Ø50 and Ø63
or with drilling machine.*



Art. 1498MT

Impugnatura a "T" intercambiabile
(per utilizzo con articolo 1498US)
*Interchangeable "T" handle
(to be used with article 1498US)*

TIEMME Raccorderie S.p.A. si riserva di apportare modifiche in qualsiasi momento senza preavviso.
TIEMME Raccorderie S.p.A. reserves the right to modify contents in any time without prior advise.
È vietata qualsiasi forma di riproduzione, se non autorizzata.
is forbidden any reproduction unless under TIEMME autorization



TIEMME Raccorderie S.p.A.
Via Cavallera 6/A (Loc. Barco) - 25045 Castagnato (Bs) - Italy
Tel +39 030 2142211 R.A. - Fax +39 030 2142206
info@tiemme.com - www.tiemme.com

©TIEMME Raccorderie S.p.A. 1498 Rev. B 10-11

