



TIEMME

VALVOLE A SQUADRA per collettori Angle valves for manifolds

Art. 2180CPR

Valvole a sfera a squadra PN 30 a passaggio totale con estremità filettata femmina e bocchettone maschio UNI ISO 228 realizzato con con pre-tenuta.

Disponibile con farfalla rossa o blu in alluminio.

Full bore angle ball valves PN 30 with threaded female and tail male ends UNI ISO 228 with o-ring. Available with red or blue aluminium "T" handle.

Si adatta ad ogni tipo di impianto idraulico domestico e commerciale, applicazioni industriali ed agricole, impianti di riscaldamento ed igienico sanitari, aria compressa, olii vari, prodotti petroliferi, generalmente con ogni fluido non corrosivo.

Suitable for domestic and commercial plumbing, industrial and agricultural applications, heating and sanitary systems, pneumatic systems, oils, generally with every non aggressive fluid.



Per la gamma completa vedere il catalogo / For complete range see catalogue



Certificazioni / Certifications

Caratteristiche Tecniche

Temperatura max di esercizio: 120 °C
Temperatura min di esercizio: -20°C
Pressione max di esercizio: vedere tabella dimensioni
Filettatura: femmina UNI ISO 228
maschio UNI ISO 228

Technical Features

Maximum temperature: 120°C
Minimum temperature: -20°C
Maximum operating pressure: See dimensional table
Threads: female UNI ISO 228
male UNI ISO 228

Descrizione

Corpo
Sfera
Stelo
Codolo e girello
O-rings
Guarnizioni laterali
Farfalla
Dado
Guarnizione piana

Materiale

Ottone CW617N - EN12165
Ottone CW617N - EN12164
Ottone CW617N - EN12164
Ottone CW617N - EN12165
Gomma nitrilica NBR
P.T.F.E.
Alluminio
Acciaio
Fasit 202

Trattamento

Nichelato
Cromato
Nichelato
Nichelato
-
-
Verniciato
Zincato
-

Description

Body
Ball
Stem
Tail and nut
O-ring
Side washers
Butterfly handle
Nut
Flat washer

Material

CW617N-EN12165 brass
CW617N-EN12164 brass
CW617N-EN12164 brass
CW617N-EN12165 brass
Nitrile rubber NBR
P.T.F.E.
Aluminium
Steel
Fasit 202

Treatment

Nickel plated
Chromium plated
Nickel plated
Nickel plated
-
-
Painted
Zinc plated
-

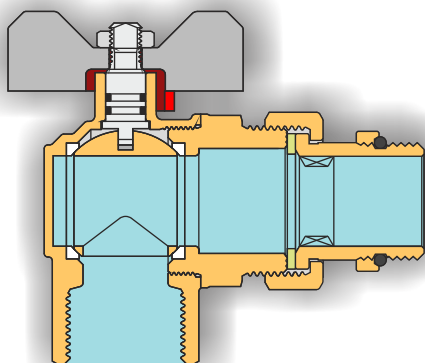

TIEMME Raccorderie S.p.A. si riserva di apportare modifiche in qualsiasi momento senza preavviso.
TIEMME Raccorderie S.p.A. reserves the right to modify contents in any time without prior advise.
È vietata qualsiasi forma di riproduzione, se non autorizzata.
Is forbidden any reproduction unless under TIEMME autorization





TIEMME

VALVOLE A SQUADRA per collettori Angle valves for manifolds

Art. 2180CPR



Tabella dimensioni
Sizes table

Size	3 / 4"	1"
Ø (DN)	20	25
A	65	65
B	48	52,5
CH	37	46
D	37	45
E	18	20,5
Em	10	10,5
L	83	100
PN	30	30



Diagramma pressione / temperatura
Pressure / temperature diagram

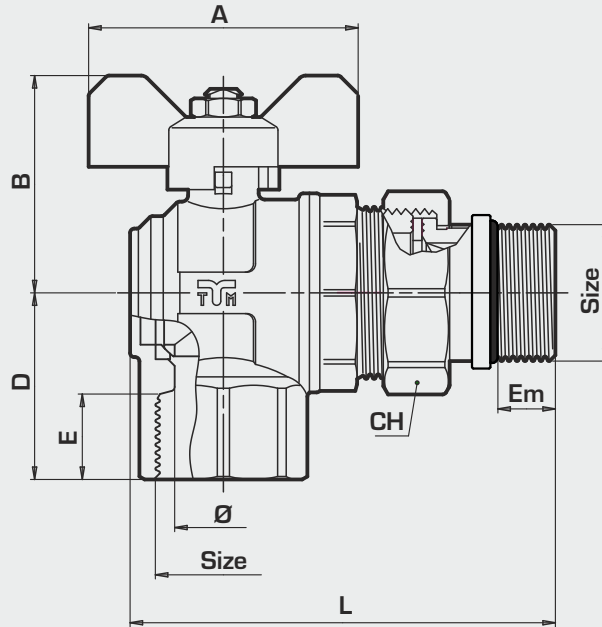

Diagramma portata/perdita di carico
Flow/pressure drop diagram



TIEMME Raccorderie S.p.A. si riserva di apportare modifiche in qualsiasi momento senza preavviso.
TIEMME Raccorderie S.p.A. reserves the right to modify contents in any time without prior advise.
È vietata qualsiasi forma di riproduzione, se non autorizzata.
is forbidden any reproduction unless under TIEMME autorization

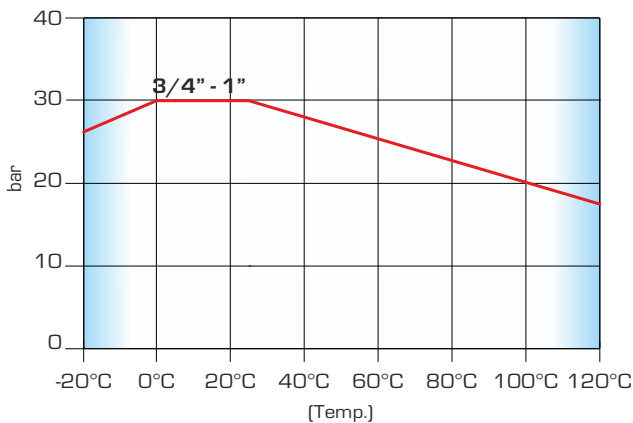
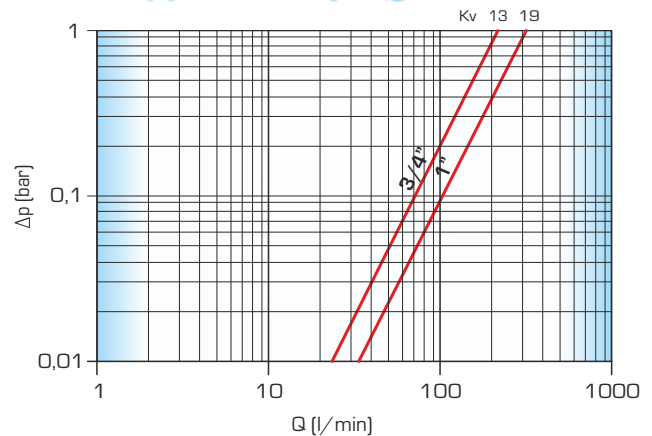

TIEMME Raccorderie S.p.A.
Via Cavallera 6/A (Loc. Barco) - 25045 Castegnato (Bs) - Italy
Tel +39 030 2142211 R.A. - Fax +39 030 2142206
info@tiemme.com - www.tiemme.com

©TIEMME Raccorderie S.p.A. 2180CPR Rev. B 10-11





TIEMME

VALVOLE A SQUADRA per collettori *Angle valves for manifolds*

Art. 2180CPR

Istruzioni per l'installazione *Installation instructions*

Le valvole possono essere montate in qualsiasi posizione (orizzontale, verticale, ...) purchè siano visibili, accessibili e le operazioni di manovra possano essere facilmente eseguite fino alla completa chiusura e/o apertura.

Salvo diversamente indicato la chiusura della valvola avviene in senso orario e l'apertura in senso anti-orario.

La direzione di montaggio della valvola rispetto al flusso del circuito è indifferente se non diversamente specificato con l'apposizione di specifiche marcature (generalmente frecce) sul corpo valvola.

L'impianto deve essere progettato e realizzato in modo tale da evitare sollecitazioni tali da danneggiare la valvola ed impedirne la corretta tenuta ed il buon funzionamento.

Le operazioni di collegamento tra la valvola e la raccorderia di connessione all'impianto devono essere eseguite con attrezzature idonee. La coppia di serraggio deve essere tale da garantire la corretta tenuta senza arrecare danneggiamenti alla valvola od ai raccordi.

Ad installazione completata è necessario eseguire la verifica delle tenute secondo quanto specificato dalle norme tecniche e/o dalle leggi vigenti nel paese di utilizzo.

La valvola non va tenuta in posizione intermedia per lunghi periodi onde evitare danneggiamenti degli organi di tenuta della valvola stessa.

In caso di lunga inattività della valvola è possibile che la manovrabilità risulti difficile pertanto si rende necessario l'utilizzo di "leve lunghe" per facilitarne l'apertura e/o chiusura.

Per mantenere la valvola ed i relativi organi di tenuta in buone condizioni e suggerito installare un filtro per la raccolta di eventuali impurità a monte della valvola.

Tiemme Raccorderie SpA declina ogni responsabilità in caso di guasti e/o incidenti qualora l'installazione non sia stata realizzata in conformità con le norme tecniche e scientifiche in vigore ed in conformità a manuali, cataloghi e/o relative disposizioni tecniche indicate da Tiemme Raccorderie SpA.

Per qualsiasi ulteriore informazioni rivolgersi ai rivenditori autorizzati o direttamente a TIEMME SpA.

The valves can be installed in any position (horizontal, vertical, ...) provided that shall be placed in visible and accessible position and the open/close operations shall be easily and completely done.

Otherwise stated to close the valve the handle shall be turned clockwise, counterclockwise to open it.

Otherwise stated by specific marks on the valve body (arrows,...) there is no valve flow direction.

The system shall be designed and realised in order to avoid any stress that could damage the valve and could compromise the sealing and the correct working of the valve.

All installation operations shall be done using properly tooling. The tightenings shall be such as to guarantee the sealing but without make any damage to the valve or fittings.

Once the installation have been completed is necessary to verify the sealings according to technical specifications and/or what required by the country of installation.

The valve should not be kept in intermediate position for a long period of time in order to avoid any damages of the valve sealings.

If the valve have not been used for a long period of time it may be difficult to operate therefore it will be necessary to use a "long lever".

To kept the valve and sealings in good conditions it is suggested to place a filter upstream in order to stop impurity.

Tiemme Raccorderie SpA decline any responsibility in case of damages and/or accidents when the installation is not done in conformity with technical and scientific rules in force and in conformity with manuals, catalogues and/or technical documentation written by Tiemme Raccorderie SpA.

For any further information please refer to your local dealer or directly to TIEMME S.p.A.

TIEMME Raccorderie S.p.A. si riserva di apportare modifiche in qualsiasi momento senza preavviso.
TIEMME Raccorderie S.p.A. reserves the right to modify contents in any time without prior advise.
È vietata qualsiasi forma di riproduzione, se non autorizzata.
is forbidden any reproduction unless under TIEMME autorization



TIEMME Raccorderie S.p.A.
Via Cavallera 6/A (Loc. Barco) - 25045 Castegnato (Bs) - Italy
Tel +39 030 2142211 R.A. - Fax +39 030 2142206
info@tiemme.com - www.tiemme.com

©TIEMME Raccorderie Sp.A. 2180CPR Rev. B 10-11

